

VAMOS REFAZER AQUELA TELONA DA

QUASE ISSO...





1. ENTENDER DE NEGÓCIOS E DO FUTURO



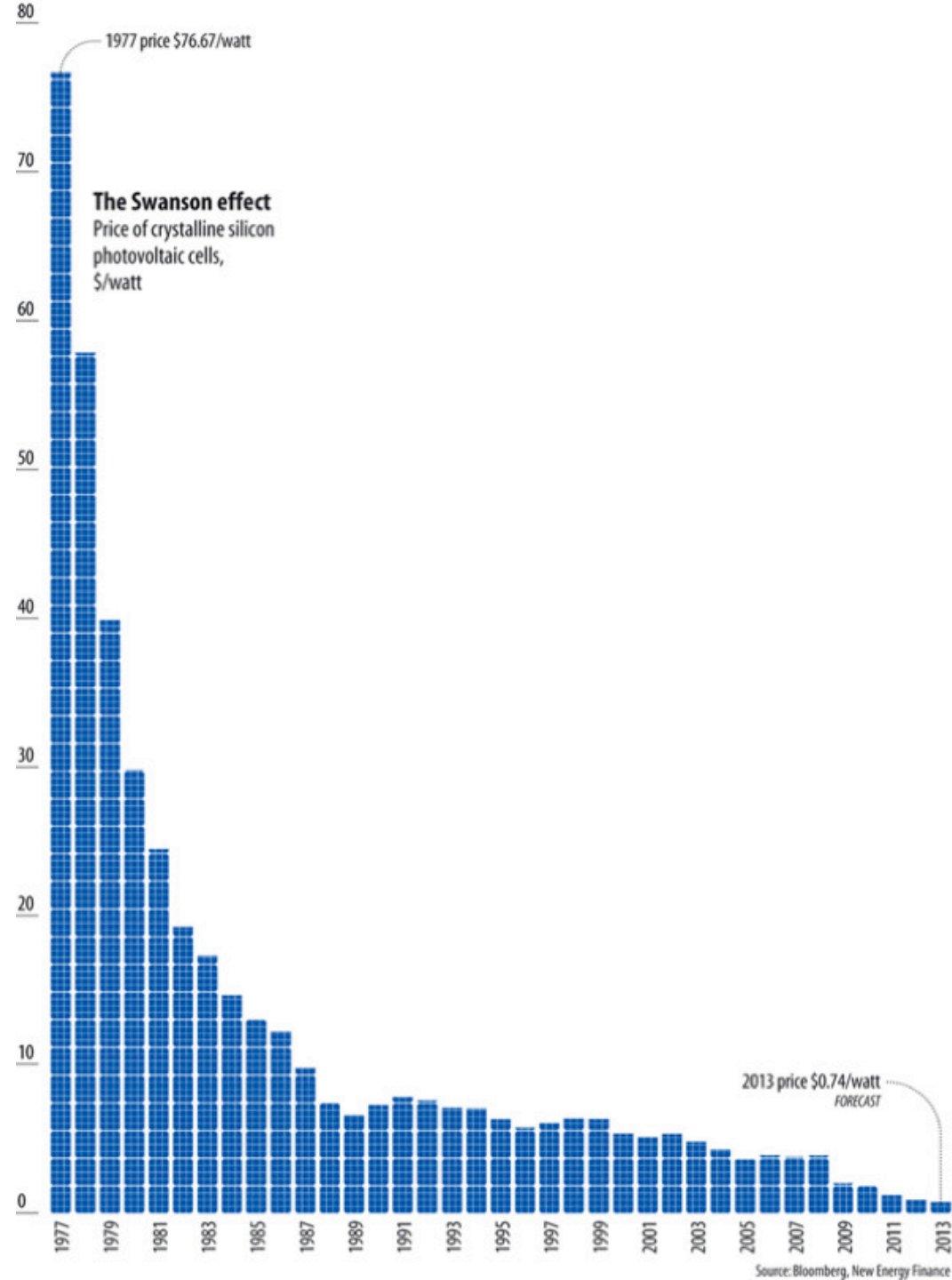

Number of Blockchain wallet users worldwide from 3rd quarter 2011 to 4th quarter 2016

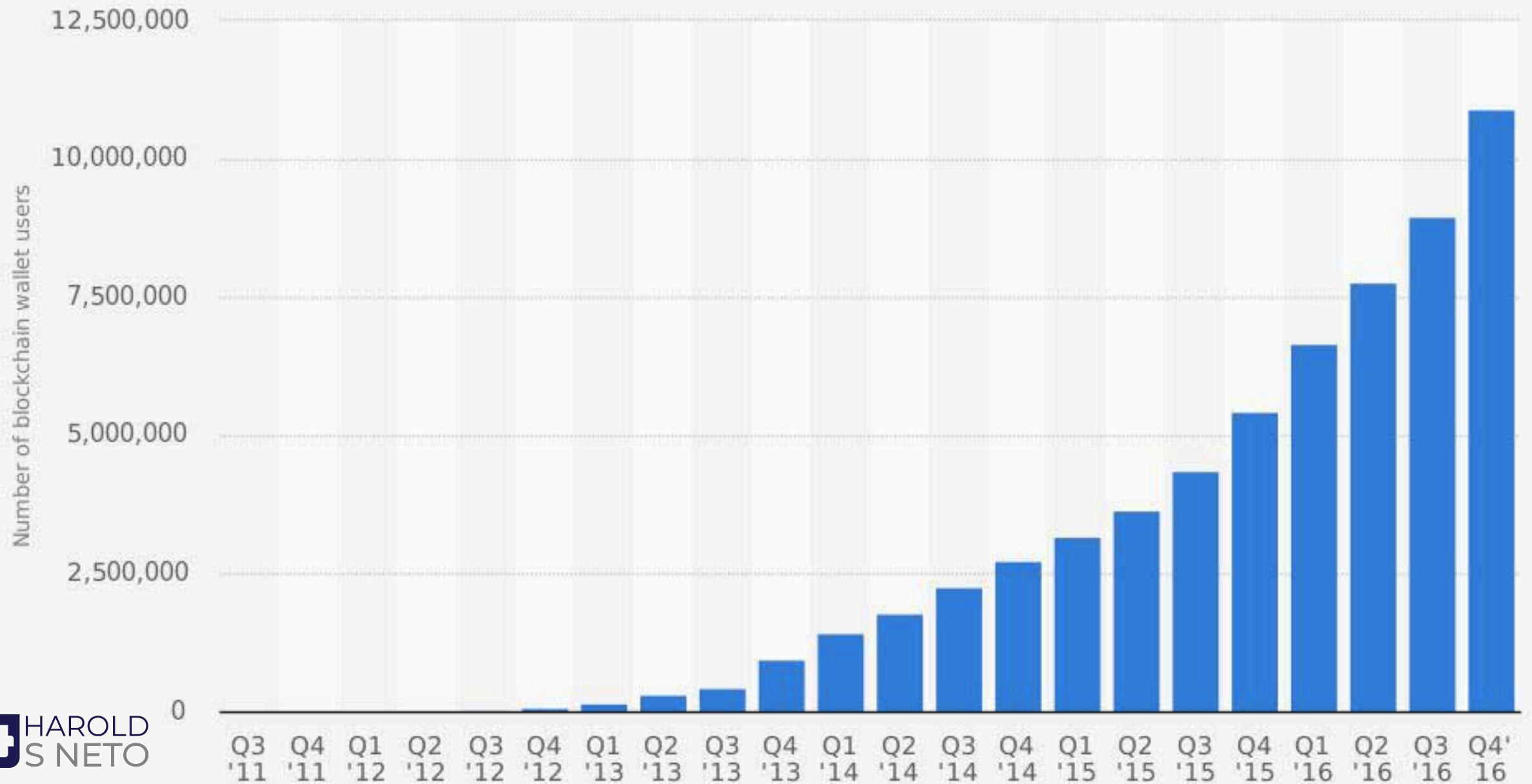





2. REPERTÓRIO É A CHAVE DO SUCESSO

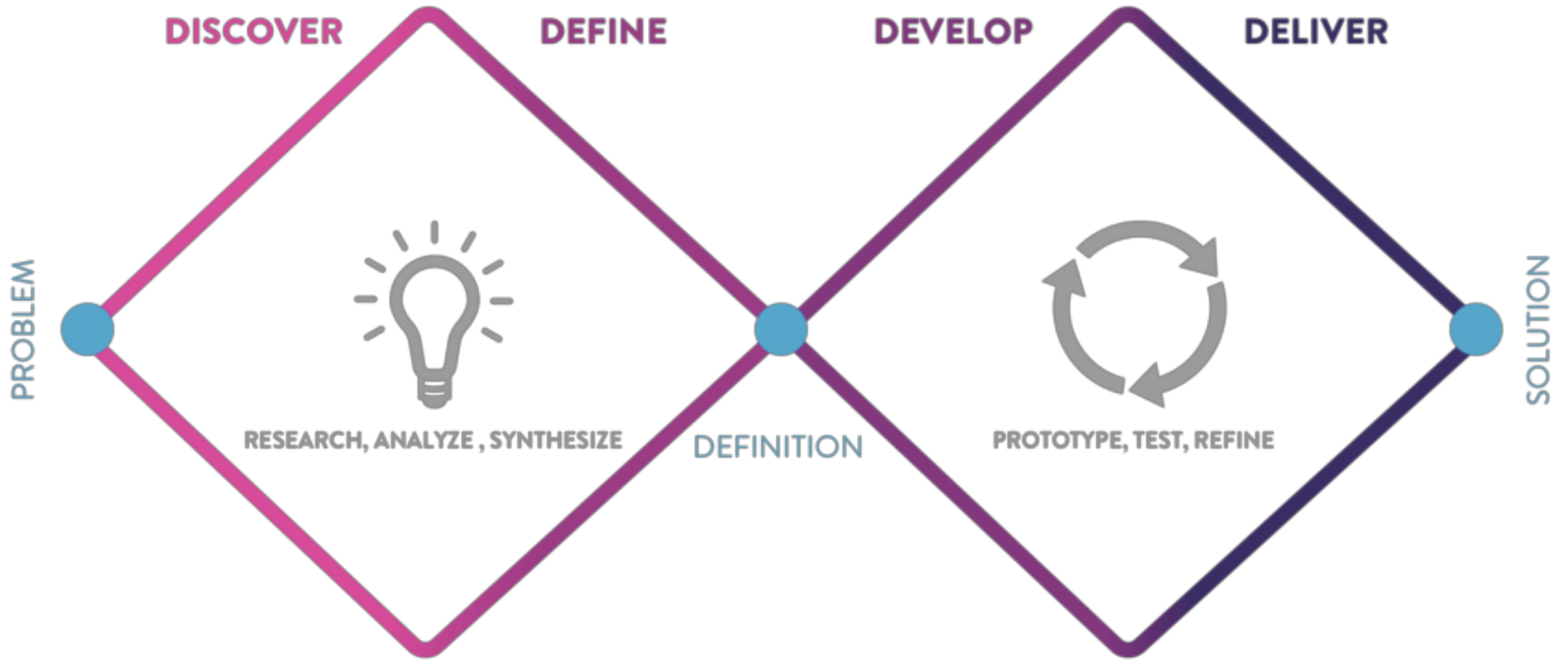



4 LENTES DA INOVAÇÃO

Expandir o entendimento do problema é parte crucial de processos de inovação. Neste exercício olhamos para o problema através de quatro lentes: Desafiar as Ortodoxias, Aproveitar as Tendências, Alavancar os Recursos, Necessidades não Atendidas.

COMO NOSSAS COMPETÊNCIAS PODEM NOS AJUDAR A SUPERAR ORTODOXIAS?

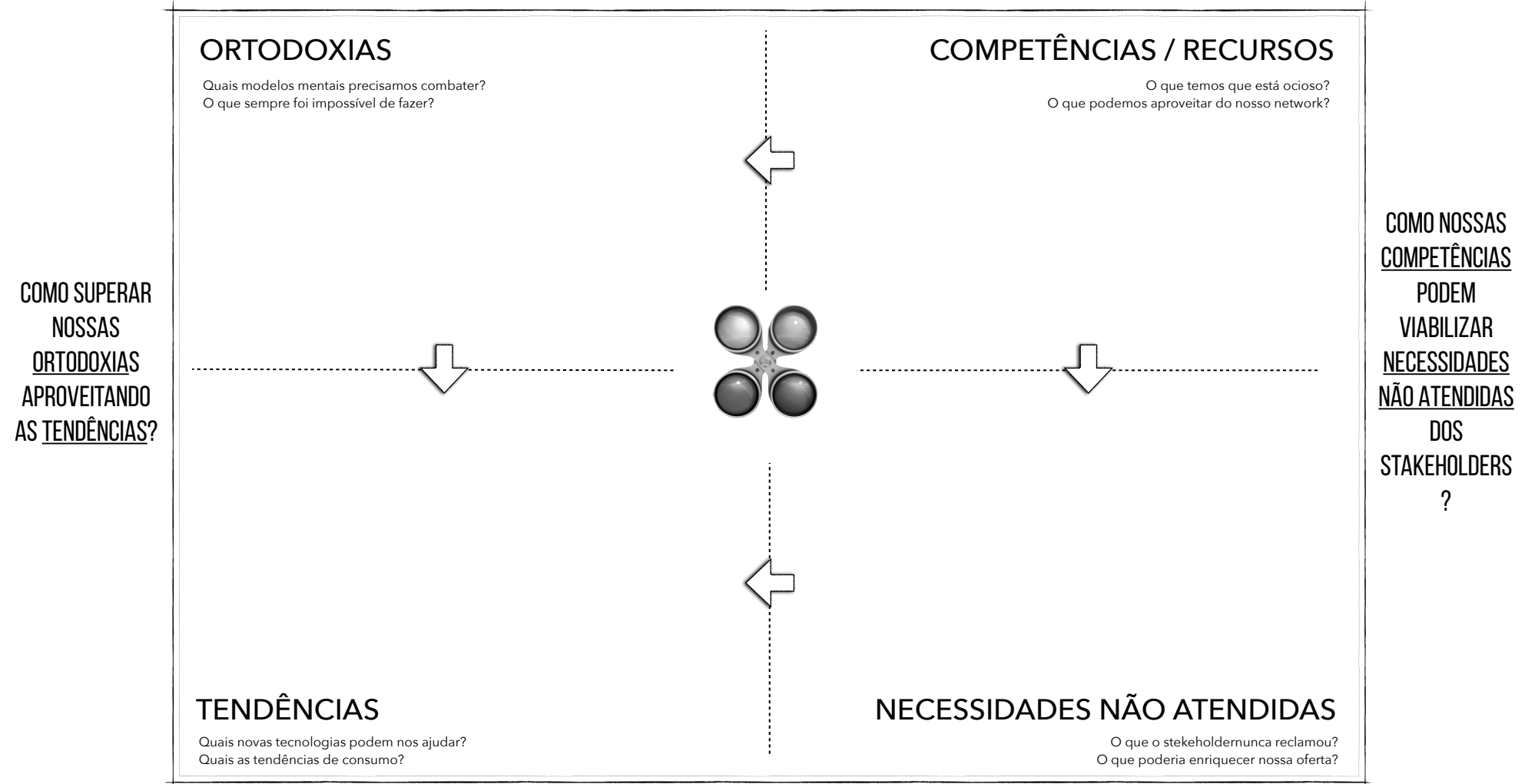

COMO COMBINAR NECESSIDADES NÃO ATENDIDAS COM TENDÊNCIAS?





3. JTBD + BEHAVIORAL + FLAT =
NEM TUDO PRECISA SER BONITO

16:26:49

Resource 440 kW

20:260

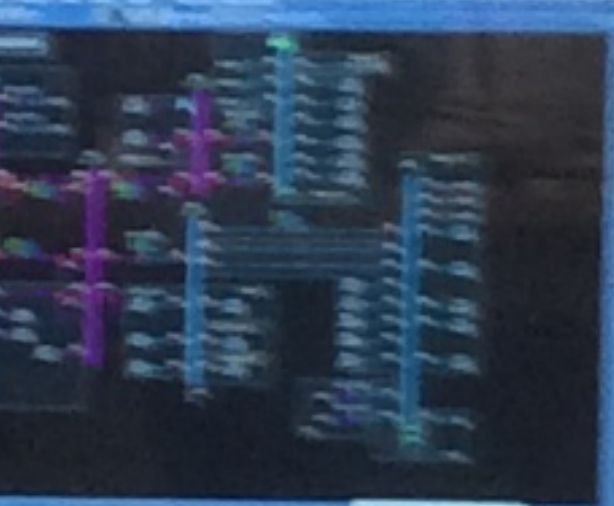
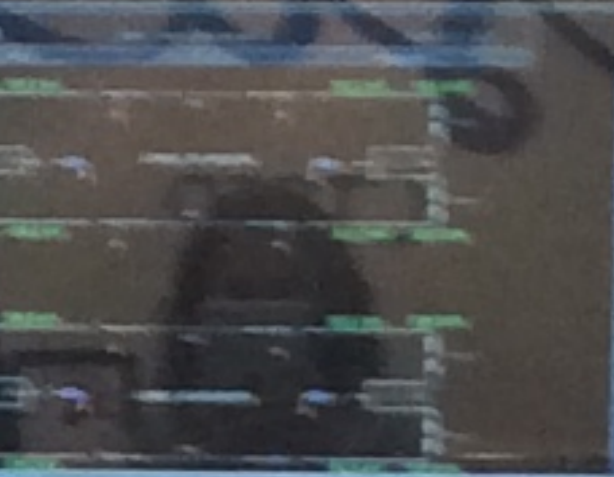

Text area containing illegible information, possibly a log or data feed.



440 kV

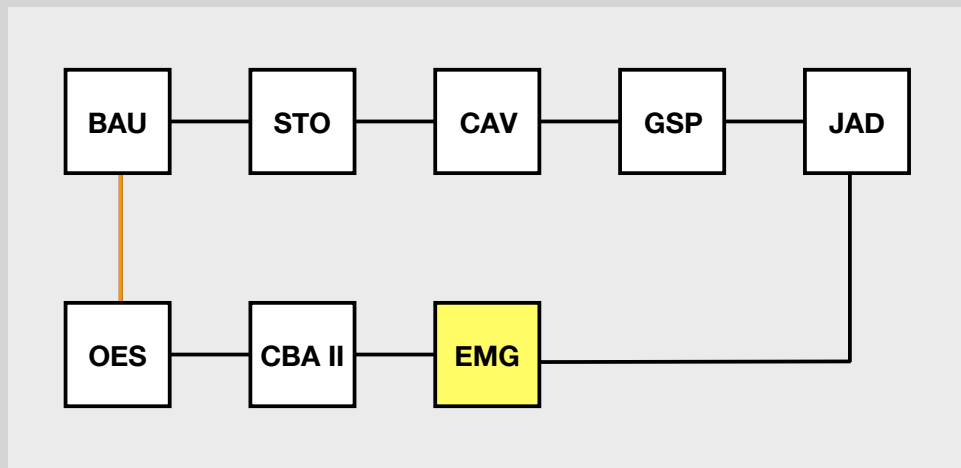
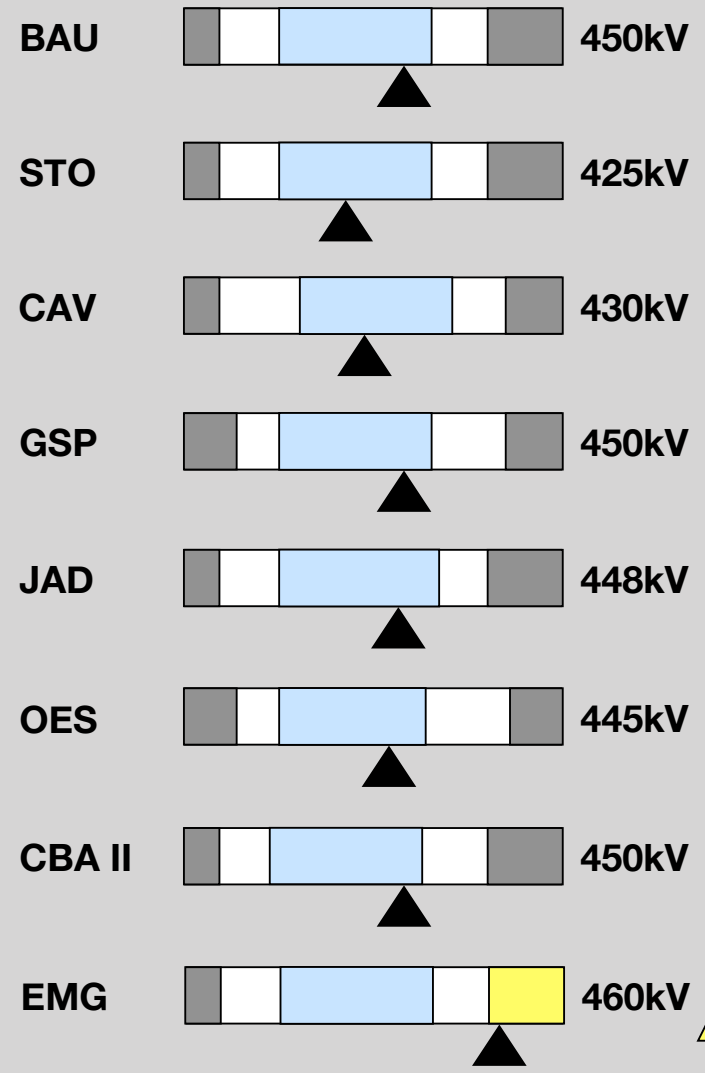

1

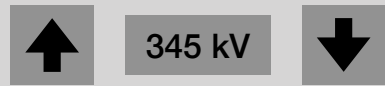
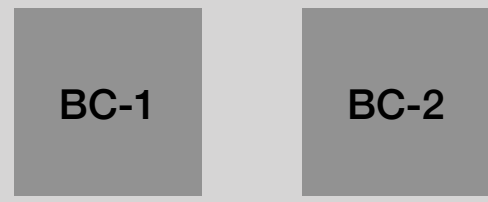
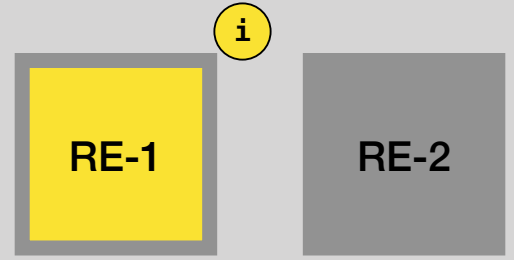
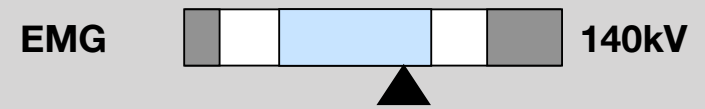

138 kV

440kV → 345kV

440kV → 138kV

0 Mvar

100 Mvar

CS-1

Painel de Manobras

PM	STATUS
TOTIB/01903/18	Solicitada
TOTIT/01350/18	Solicitada
TOTIC/01382/18	Solicitada
TOTIT/01403/18	Finalizada
TOTIT/01398/18	Iniciada
TOTIC/01328/18	Solicitada
TOTIT/01401/18	Não Solicitada
TOTIB/01848/18	Não Solicitada
TOTIC/01322/18	Não Solicitada
TOTIB/01909/18	Não Solicitada
TOTIS/01660/18	Não Solicitada

TOTIT/01403/18

- 1- COT - BLOQUEAR RELÉ 79 DA LT 138 kV PAR/CAU C-1
- 2- CAU - DESLIGAR 20552-3
- 3- PAR - DESLIGAR 2552-7
- 4- PAR - ABRIR OU MANTER ABERTOS 2529-54, 56, 60 E 62
- 5- CAU - ABRIR 20529-14 E 18
- 6- CAU - MANTER ABERTO 20529-16
- 7- PAR - FECHAR CHAVE DE ATERRAMENTO 2529-5
- 8- CAU - BLOQUEAR 20529-14
- 9- PAR - BLOQUEAR 2529-5, 54 E 56



4. TEM \$\$\$\$\$ NA MESA

Contexto Legal

Origem - Lei # 9.991, 24 de julho de 2000

- *Política pública de estímulo à Pesquisa e Desenvolvimento e à Eficiência Energética no setor de energia elétrica, por meio da aplicação compulsória de recursos provenientes da Receita Operacional Líquida (ROL) das empresas do setor*
- **Recursos Disponíveis:**

Segmento	P&D (% ROL)	P&D regulado pela ANEEL
Geração	1.0 %	0.4 %
Transmissão	1.0 %	0.4 %
Distribuição	0.5 %	0.2 %

- **Investimento anual médio: Aproximadamente R\$ 380 Milhões (D+G+T)**



5. NÃO “SEJE” NUTELLA!





CUSTOMER & PARTNERS





INCREASING BUSINESS CAPABILITIES
TRANSFORMING TRADITIONAL BUSINESS MODELS

WHO CONNECTS?

INTERNATIONAL SPEAKER AND INNOVATION COACH TO SOME OF THE WORLD'S LARGEST COMPANIES. I WAS RESPONSIBLE TO TRAIN ALL CISCO'S INNOVATION CENTER TEAM MEMBERS AROUND THE WORLD. I AM A CERTIFIED EXO COACH AND AMBASSADOR FOR OPENEXO AND HAVE CONTRIBUTED TO THE BOOK "EXPONENTIAL TRANSFORMATION". CO-FOUNDER OF ZEESTER, A VENTURE BUILDER DEDICATED TO CREATE HIGH IMPACT STARTUPS WITH EXPONENTIAL GROWTH. I AM THE CREATOR OF NEEMIAS.ORG AN ONLINE COMMUNITY FOR CHRISTIAN ENTREPRENEURS.

AS A MEMBER OF THE TEAM OF DESIGNSPRINTSCHOOL.COM I WAS THE LEAD MENTOR FOR A YEAR GUIDING OVER 100 STUDENTS TO RESHAPE THEIR WAY OF THINKING THROUGH THE LENSES OF DESIGN, CURRENTLY I MENTOR STUDENTS AT AWARI DESIGN COURSE.

FUN FACT IN 2017 I HAD THE CHANCE TO SLEEP ONE NIGHT AT BAUHAUS, THE BIRTHPLACE OF DESIGN.



CERTIFICATIONS



UX CERTIFIED



SPRINT MASTER MENTOR



EXO AMBASSADOR



EXO COACH



#HACKINGYOURPUZZLES

